

NO	DATE	REVISIONS	ECO NO.	DR	CK
	20221017	PROTO RELEASED	E1ABT0001	ZGY	YJU
1	20221221	CHANGED	E1ABT0003	MJJ	YJU

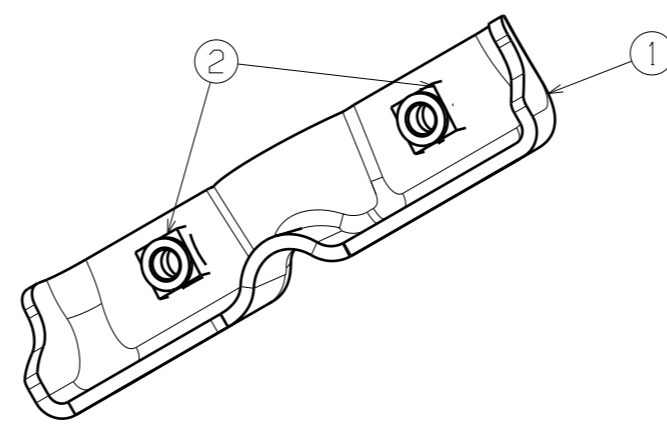
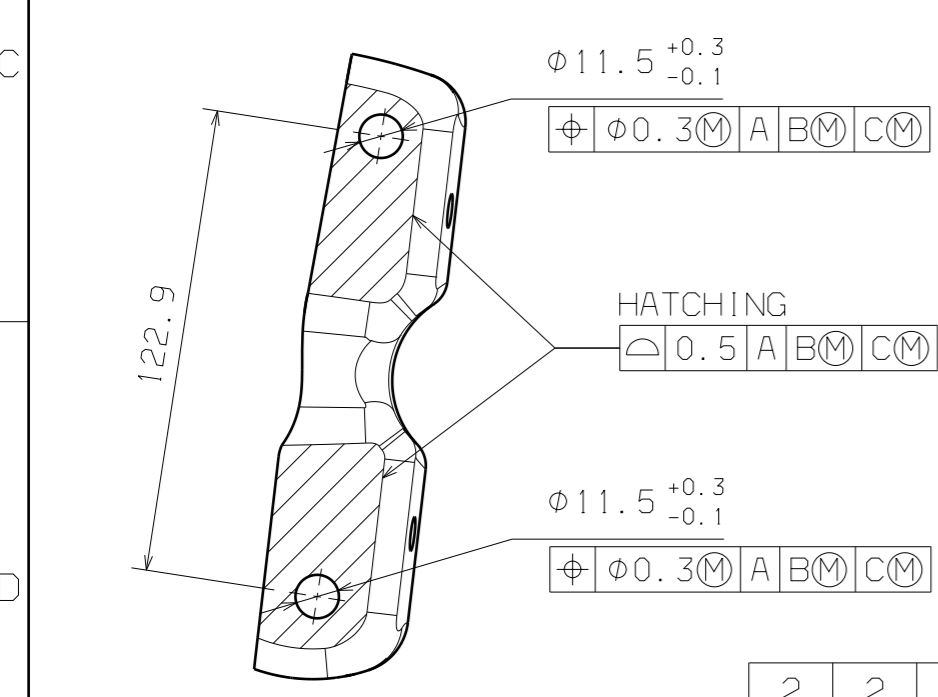
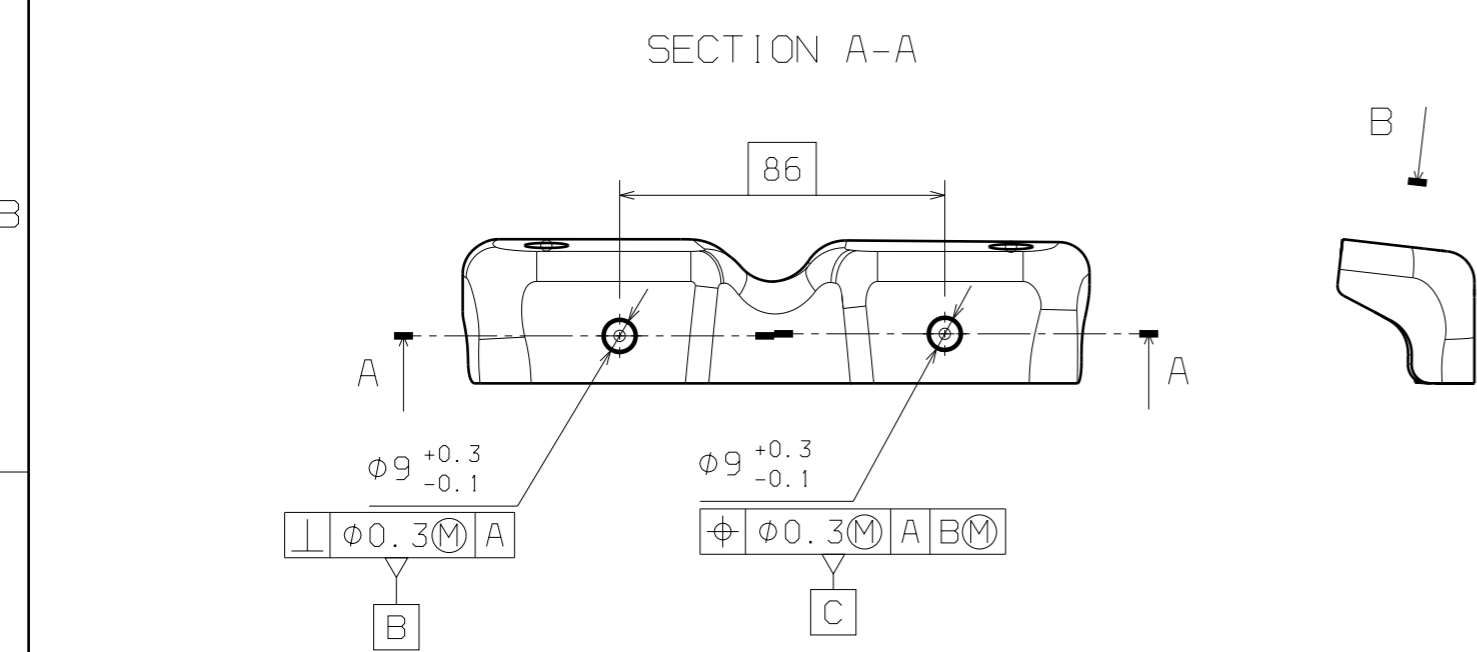
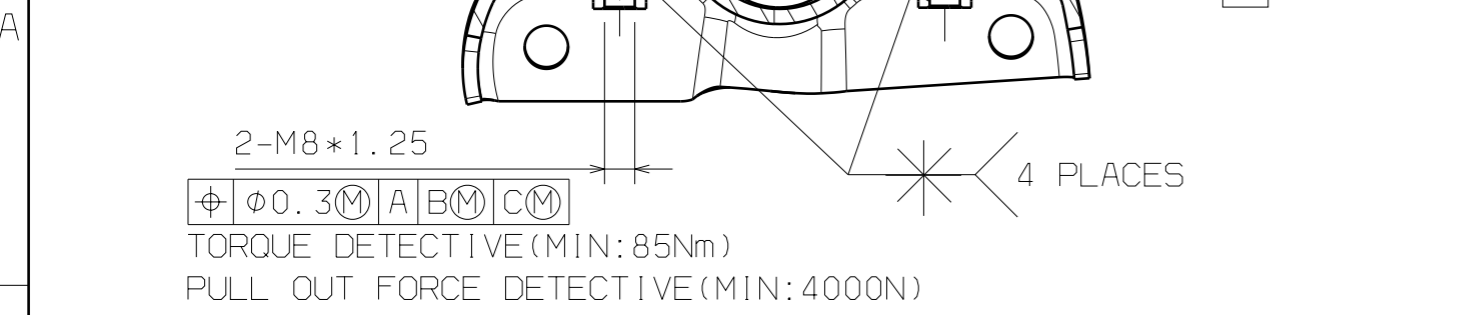

Front view

2	2	SJT075278	WELD-NUT-M8	M8*1.25, 10B21
1	1	XLSJSY00034	STAY-1	SUH409L, 4t
QTY	NO.	PART NO	PART NAME	MATL REMARKS

技术要求 (Technical requirements)

1. 未标注的尺寸参照3D模型。  
UNSPECIFIED DIMENSIONS SHOULD BE CONFORM TO 3D DATA.
2. 零件必须无拉伤、压痕、毛刺、开裂、褶皱、油渍。  
PART MUST BE NO STRAIN, INDENTATION, BURR, CRACK, WRINKLE, GREASE.
3. 禁用/限用物质法规要求: 国内满足Q/SQR SEI-5, 欧盟和北美满足2000/53/EC, 2005/64/EC, 1907/2006/EC。  
LEGAL REQUIREMENTS FOR PROHIVITED/RESTRICTED HAZARDOUS SUBSTANCES:  
EOMESTIC MEET Q/SQR SEI-5  
THE DUROPEAN UNION AND NORTH AMERICA TO MEET 2000/53/EC, 2005/64/EC, 1907/2006/EC, GADSL, Q/SQR SEI-5.
4. 最终厚度 (包括加工之后的厚度) 变化率必须控制在20%以内。  
THE DECREMENT OF THICKNESS MUST BE UNDER 20% AFTER FORMING.
5. 未标注的表面轮廓度公差。  
ALL GENERAL SURFACES:  $\triangle 1 \text{ A (BM)} \text{ C (M)}$   
未标注的圆形、圆柱型、球型位置度公差。  
ALL CIRCULAR/CYLINDRICAL/SPHERICAL FEATURES OF SIZE:  $\phi 1 \text{ (M)} \text{ A (BM)} \text{ C (M)}$
6. 焊接标准: GB/T 12467.1~12467.4-2009  
WELDING STANDARD SHOULD FOLLOW GB/T 12467.1~12467.4-2009

<b>世 钟 工 业 株 式 会 社</b> SE JONG IND CO., LTD					
参考 (REFERENCE)		部 门	CHINA R&D	日期 (DATE)	2022.10.17
制图 (DRAWN)	检查 (CHECKED)	承认 (APPROVED)	承认 (APPROVED)	不要缩放 DO NOT SCALE	
MJJ			YJU	数量 (Q'TY)	重量 (WT) kg
指定公差 (UNLESS OTHERWISE SPECIFIED)			1		0.344
GB/T 1184-1996-L			比例 (SCALE)		
GB/T 1804-2000-C			1:2		
材质 (MATERIAL)			SEE BOM		承认 (APP'V)
车型 (PROJECT)			CHERY JX67 1.5TD		第 1 视角 PROJECTION 1ST ANGLE
品名 (PART NAME)			STAY-1-ASSY		
品号 (PART NO.)			XLSJSY00034-S		单位 : mm DIMENSION : MILLIMETER
图纸尺寸 (FORM)			ISO-A3		每 (SHT)
					1
					1 每种 (SHTS)